

MAX-BAR 6mm 35° SERIES TOOLING



CUT-OFF

(REG. U.S. PATENT)
 (NO. 5,779,400)
 (NO. 6,033,158)

WITH ONE TOOLHOLDER
 JUST CHANGE INSERT

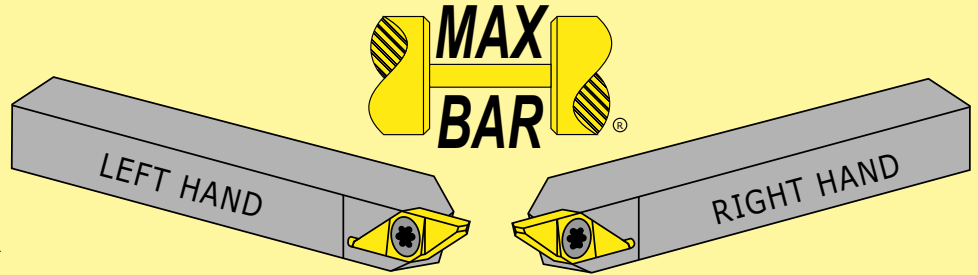

CUT-OFF

RIGHT HAND SHOWN

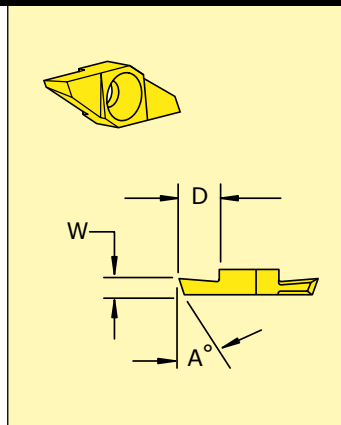

R.H. INSERT NO.	L.H. INSERT NO.	A°	WIDTH		DEPTH	
			INCH	MM	INCH	MM
VCOR-6M2520	VCOL-6M2520	25°	.020	0,50	.050	1,30
VCOR-6M2525	VCOL-6M2525	25°	.025	0,63	.065	1,65
VCOR-6M2531	VCOL-6M2531	25°	.031	0,78	.090	2,30
VCOR-6M2040	VCOL-6M2040	20°	.040	1,00	.100	2,60
VCOR-6M2047	VCOL-6M2047	20°	.047	1,20	.130	3,30
VCOR-6M1562	VCOL-6M1562	15°	.062	1,57	.160	4,06
VCOR-6M1578	VCOL-6M1578	15°	.078	1,98	.200	5,00
VCOR-6M1593	VCOL-6M1593	15°	.093	2,36	.200	5,00

OPP. HAND CUT-OFF

RIGHT HAND WITH LEFT HAND CUT-OFF SHOWN

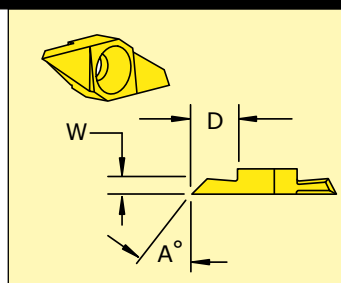

OPP. HAND CUT-OFF
 FOR PICKOFF SPINDLE

R.H. INSERT NO.	L.H. INSERT NO.	A°	WIDTH		DEPTH	
			INCH	MM	INCH	MM
VCORL-6M2531	VCOLR-6M2531	25°	.031	0,78	.090	2,30
VCORL-6M2040	VCOLR-6M2040	20°	.040	1,00	.100	2,60
VCORL-6M2047	VCOLR-6M2047	20°	.047	1,20	.130	3,30
VCORL-6M1562	VCOLR-6M1562	15°	.062	1,57	.160	4,06
VCORL-6M1578	VCOLR-6M1578	15°	.078	1,98	.200	5,00
VCORL-6M1593	VCOLR-6M1593	15°	.093	2,36	.200	5,00

TOOLHOLDERS

RIGHT HAND SHOWN

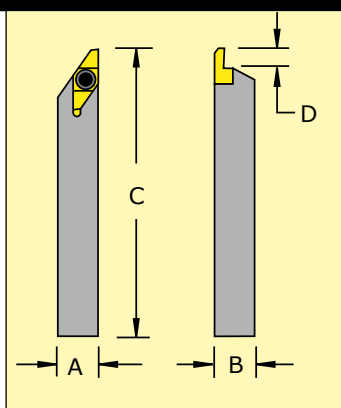

R.H. HOLDER NO.	L.H. HOLDER NO.	A	B	C	D
SVANR-07M6M-C	SVANL-07M6M-C	7mm	7mm	127mm	5mm
SVANR-08M6M-C	SVANL-08M6M-C	8mm	8mm	127mm	5mm
SVANR-10M6M-C	SVANL-10M6M-C	10mm	10mm	127mm	5mm
SVANR-12M6M-C	SVANL-12M6M-C	12mm	12mm	127mm	5mm
SVANR-3756M-C	SVANL-3756M-C	.375	.375	5.00	.200
SVANR-5006M-C	SVANL-5006M-C	.500	.500	5.00	.200
SVANR-6256M-C	SVANL-6256M-C	.625	.625	5.00	.200
SVANR-7506M-C	SVANL-7506M-C	.750	.750	5.00	.200
SPARE PARTS	SCREW 2.40-064	WRENCH T-7			

MAX-BAR 8mm 35° SERIES TOOLING

(FORMERLY 2.5 SERIES)



CUT-OFF

RIGHT HAND SHOWN

R.H. INSERT NO.	L.H. INSERT NO.	WIDTH		DEPTH		A°
		INCH	MM	INCH	MM	
VCOR-8M158	VCOL-8M158	.125	3,18	.320	8,13	15°
VCOR-8M156	VCOL-8M156	.093	2,36	.320	8,13	15°
VCOR-8M155	VCOL-8M155	.078	1,98	.320	8,13	15°
VCOR-8M154	VCOL-8M154	.062	1,57	.260	6,60	15°
VCOR-8M153	VCOL-8M153	.047	1,19	.190	4,83	15°
VCOR-8M201M	VCOL-8M201M	.040	1,00	.130	3,30	20°
VCOR-8M202	VCOL-8M202	.031	0,78	.080	2,03	20°

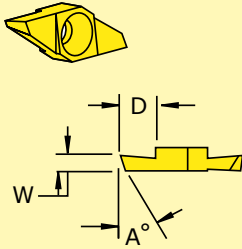

OPP. HAND CUT-OFF

RIGHT HAND INSERT WITH LEFT HAND CUT-OFF SHOWN

R.H. INSERT NO.	L.H. INSERT NO.	WIDTH		DEPTH		A°
		INCH	MM	INCH	MM	
VCORL-8M158	VCOLR-8M158	.125	3,18	.320	8,13	15°
VCORL-8M156	VCOLR-8M156	.093	2,36	.320	8,13	15°
VCORL-8M155	VCOLR-8M155	.078	1,98	.320	8,13	15°
VCORL-8M154	VCOLR-8M154	.062	1,57	.260	6,60	15°
VCORL-8M153	VCOLR-8M153	.047	1,19	.190	4,83	15°
VCORL-8M201M	VCOLR-8M201M	.040	1,00	.130	3,30	20°

FOR PICKOFF SPINDLE

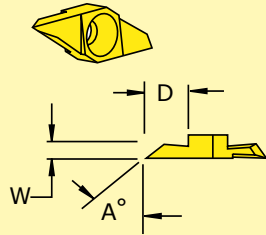

TOOLHOLDERS

RIGHT HAND SHOWN

R.H. HOLDER NO.	L.H. HOLDER NO.	A	B	C	D
SVANR-3758M-V	SVANL-3758M-V	.375	.375	3.50	.380
SVANR-3758M-C	SVANL-3758M-C	.375	.375	5.00	.380
SVANR-10M8M-C	SVANL-10M8M-C	10mm	10mm	127mm	10mm
SVANR-12M8M-C	SVANL-12M8M-C	12mm	12mm	127mm	12mm
SVANR-5008M-V	SVANL-5008M-V	.500	.500	3.50	.505
SVANR-5008M-C	SVANL-5008M-C	.500	.500	5.00	.505
SVANR-6258M-C	SVANL-6258M-C	.625	.625	5.00	.630
SPARE PARTS	SCREW 3.20-095	WRENCH T-10			

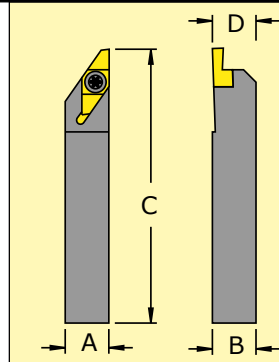

MAX-BAR 10 SERIES TOOLING

FOR BAR DIAMETERS UP TO 3/8" (10mm)



CUT-OFF

RIGHT HAND SHOWN

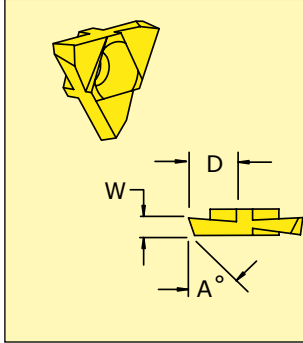

R.H. INSERT NO.	L.H. INSERT NO.	WIDTH		DEPTH		A°
		INCH	MM	INCH	MM	
TCOR-3158	TCOL-3158	.125	3,18	.230	5,84	15°
TCOR-3156	TCOL-3156	.093	2,36	.230	5,84	15°
TCOR-3155	TCOL-3155	.078	1,98	.230	5,84	15°
TCOR-3154	TCOL-3154	.062	1,57	.230	5,84	15°
TCOR-3153	TCOL-3153	.047	1,19	.230	5,84	15°
TCOR-3201M	TCOL-3201M	.040	1,00	.180	4,57	20°
TCOR-3202	TCOL-3202	.031	0,78	.100	2,54	20°

OPP. HAND CUT-OFF

LEFT HAND INSERT WITH RIGHT HAND CUT-OFF SHOWN

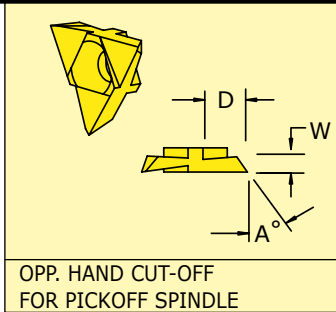

R.H. INSERT NO.	L.H. INSERT NO.	WIDTH		DEPTH		A°
		INCH	MM	INCH	MM	
TCORL-3156	TCOLR-3156	.093	2,36	.230	5,84	15°
TCORL-3155	TCOLR-3155	.078	1,98	.230	5,84	15°
TCORL-3154	TCOLR-3154	.062	1,57	.230	5,84	15°
TCORL-3153	TCOLR-3153	.047	1,19	.230	5,84	15°
TCORL-3201M	TCOLR-3201M	.040	1,00	.180	4,57	20°
TCORL-3202	TCOLR-3202	.031	0,78	.100	2,54	20°

TOOLHOLDERS

RIGHT HAND SHOWN

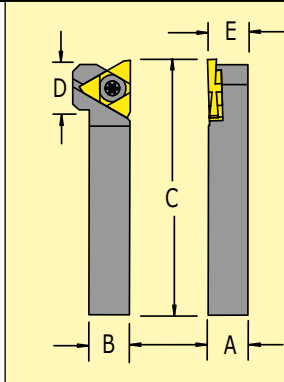

R.H. Holder No.	L.H. Holder No.	A	B	C	D	E
STANR-053-V	STANL-053-V	.312	.312	3.50	.550	.317
STANR-063-V	STANL-063-V	.375	.375	3.50	.550	.380
STANR-063-C	STANL-063-C	.375	.375	5.00	.550	.380
STANR-083-V	STANL-083-V	.500	.500	3.50	.550	.505
STANR-083-C	STANL-083-C	.500	.500	5.00	.550	.505
STANR-103-V	STANL-103-V	.625	.625	3.50	---	.630
SPARE PARTS		SCREW 3.50 - 095			WRENCH T-15	

MAX-BAR 16 SERIES TOOLING

FOR BAR DIAMETERS UP TO 5/8" (16mm)



CUT-OFF

RIGHT HAND SHOWN

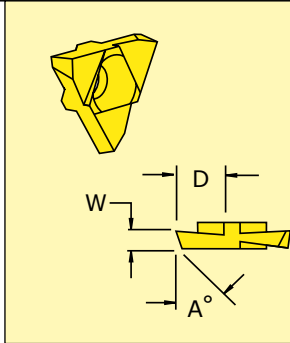

R.H. INSERT NO.	L.H. INSERT NO.	WIDTH		DEPTH		A°
		INCH	MM	INCH	MM	
TCOR-4158	TCOL-4158	.125	3,18	.370	9,40	15°
TCOR-4156	TCOL-4156	.093	2,36	.370	9,40	15°
TCOR-4155	TCOL-4155	.078	1,98	.370	9,40	15°
TCOR-4154	TCOL-4154	.062	1,57	.300	7,62	15°
TCOR-4153	TCOL-4153	.047	1,19	.230	5,84	15°
TCOR-4201M	TCOL-4201M	.040	1,00	.180	4,57	20°
TCOR-4202	TCOL-4202	.031	0,78	.100	2,54	20°

OPP. HAND CUT-OFF

LEFT HAND INSERT WITH RIGHT HAND CUT-OFF SHOWN

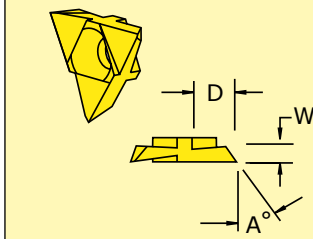

OPP. HAND CUT-OFF
FOR PICKOFF SPINDLE

R.H. INSERT NO.	L.H. INSERT NO.	WIDTH		DEPTH		A°
		INCH	MM	INCH	MM	
TCORL-4156	TCOLR-4156	.093	2,36	.370	9,40	15°
TCORL-4155	TCOLR-4155	.078	1,98	.370	9,40	15°
TCORL-4154	TCOLR-4154	.062	1,57	.300	7,62	15°
TCORL-4153	TCOLR-4153	.047	1,19	.230	5,84	15°
TCORL-4201M	TCOLR-4201M	.040	1,00	.180	4,57	20°
TCORL-4202	TCOLR-4202	.031	0,78	.100	2,54	20°

TOOLHOLDERS

RIGHT HAND SHOWN

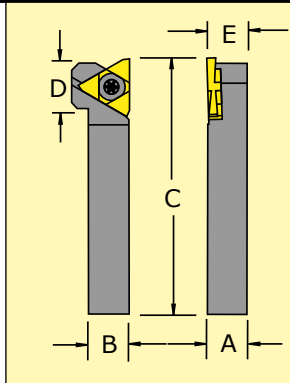

R.H. Holder No.	L.H. Holder No.	A	B	C	D	E
STANR-064-V *	STANL-064-V *	.375	.375	3.50	.750	.380
STANR-064-C *	STANL-064-C *	.375	.375	5.00	.750	.380
STANR-084-V	STANL-084-V	.500	.500	3.50	.750	.505
STANR-084-C	STANL-084-C	.500	.500	5.00	.750	.505
STANR-104-V	STANL-104-V	.625	.625	3.50	.750	.630
STANR-124-C	STANL-124-C	.750	.750	5.00	---	.755
SPARE PARTS		SCREW *4.06-095 4.06-127			WRENCH T-20	

MAX-BAR 20 SERIES TOOLING

FOR BAR DIAMETERS UP TO 3/4" (20mm)



CUT-OFF

RIGHT HAND SHOWN

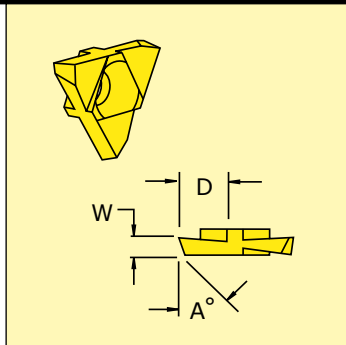

R.H. INSERT NO.	L.H. INSERT NO.	WIDTH		DEPTH		A°
		INCH	MM	INCH	MM	
TCOR-5158	TCOL-5158	.125	3,18	.440	11,2	15°
TCOR-5156	TCOL-5156	.093	2,36	.440	11,2	15°
TCOR-5155	TCOL-5155	.078	1,98	.370	9,40	15°
TCOR-5154	TCOL-5154	.062	1,57	.300	7,62	15°
TCOR-5153	TCOL-5153	.047	1,19	.230	5,84	15°
TCOR-5201M	TCOL-5201M	.040	1,00	.180	4,57	20°

OPP. HAND CUT-OFF

LEFT HAND INSERT WITH RIGHT HAND CUT-OFF SHOWN

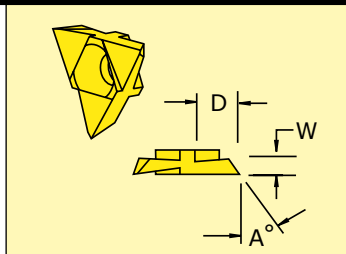

OPP. HAND CUT-OFF FOR PICKOFF SPINDLE

R.H. INSERT NO.	L.H. INSERT NO.	WIDTH		DEPTH		A°
		INCH	MM	INCH	MM	
TCORL-5158	TCOLR-5158	.125	3,18	.440	11,2	15°
TCORL-5156	TCOLR-5156	.093	2,36	.440	11,2	15°
TCORL-5155	TCOLR-5155	.078	1,98	.370	9,40	15°
TCORL-5154	TCOLR-5154	.062	1,57	.300	7,62	15°
TCORL-5153	TCOLR-5153	.047	1,19	.230	5,84	15°
TCORL-5201M	TCOLR-5201M	.040	1,00	.180	4,57	20°

TOOLHOLDERS

RIGHT HAND SHOWN

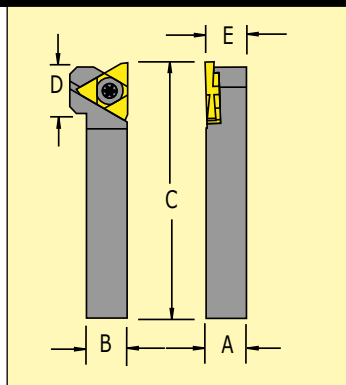

R.H. Holder No.	L.H. Holder No.	A	B	C	D	E
STANR-085-V	STANL-085-V	.500	.500	3.50	.920	.505
STANR-085-C	STANL-085-C	.500	.500	5.00	.920	.505
STANR-105-V	STANL-105-V	.625	.625	3.50	.920	.630
STANR-105-D	STANL-105-D	.625	.625	4.50	.920	.630
STANR-125-C	STANL-125-C	.750	.750	5.00	.920	.755
SPARE PARTS		SCREW 4.76-127			WRENCH T-25	

MAX-BAR 50° SERIES TOOLING



CUT-OFF

RIGHT HAND SHOWN

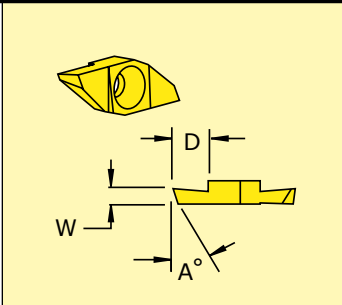

R.H. INSERT NO.	L.H. INSERT NO.	WIDTH		DEPTH		A°
		INCH	MM	INCH	MM	
KCOR-4158	KCOL-4158	.125	3,18	.320	8,13	15°
KCOR-4156	KCOL-4156	.093	2,36	.320	8,13	15°
KCOR-4155	KCOL-4155	.078	1,98	.320	8,13	15°
KCOR-4154	KCOL-4154	.062	1,57	.260	6,60	15°
KCOR-4153	KCOL-4153	.047	1,19	.190	4,83	15°
KCOR-4201M	KCOL-4201M	.040	1,00	.130	3,30	20°

OPP. HAND CUT-OFF

RIGHT HAND INSERT WITH LEFT HAND CUT-OFF SHOWN

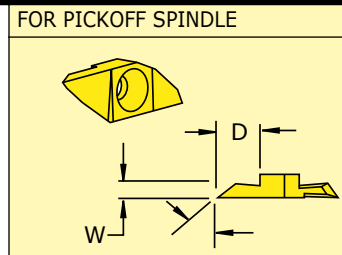

R.H. INSERT NO.	L.H. INSERT NO.	WIDTH		DEPTH		A°
		INCH	MM	INCH	MM	
KCORL-4156	KCOLR-4156	.093	2,36	.320	8,13	15°
KCORL-4155	KCOLR-4155	.078	1,98	.320	8,13	15°
KCORL-4154	KCOLR-4154	.062	1,57	.260	6,60	15°
KCORL-4153	KCOLR-4153	.047	1,19	.190	4,83	15°

TOOLHOLDERS

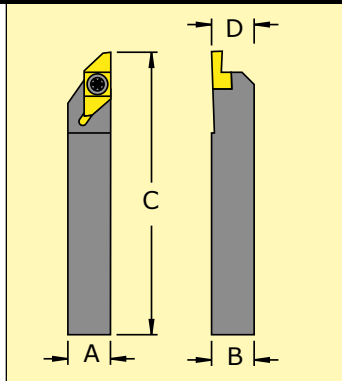

R.H. HOLDER NO.	L.H. HOLDER NO.	A	B	C	D
SKANR-104-V	SKANL-104-V	.625	.625	3.50	.630
SKANR-104-C	SKANL-104-C	.625	.625	5.00	.630
SKANR-124-V	SKANL-124-V	.750	.750	3.50	.755
SKANR-124-C	SKANL-124-C	.750	.750	5.00	.755
SKANR-164-C	SKANL-164-C	1.00	1.00	5.00	1.00
SPARE PARTS	SCREW 4.76-127	WRENCH T-25			

MAX-BAR RIGHT ANGLE HOLDERS

FOR TURRET & GANG LOADING

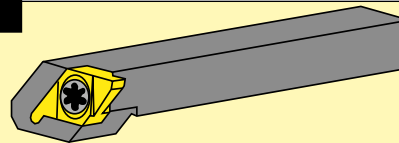
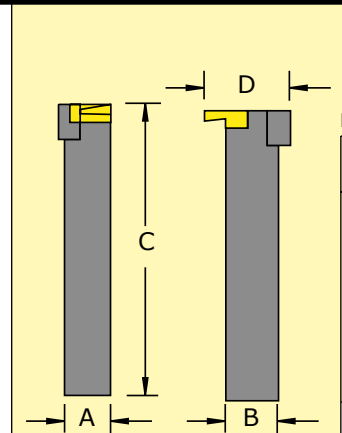

RIGHT HAND SHOWN

R.H. HOLDER NO.	L.H. HOLDER NO.	A	B	C	D	SCREW	WRENCH
SKFNR-064-D	SKFNL-064-D	.375	.500	4.50	1.15	4.76-127	T-25
SKFNR-084-D	SKFNL-084-D	.500	.500	4.50	1.15	4.76-127	T-25
SKFNR-104-D	SKFNL-104-D	.625	.625	4.50	1.15	4.76-127	T-25
SKFNR-124-C	SKFNL-124-C	.750	.750	5.00	1.05	4.76-127	T-25
SKFNR-164-C	SKFNL-164-C	1.00	1.00	5.00	1.30	4.76-127	T-25

NON-STANDARD SHANK SIZES AND RECTANGULAR SHANKS AVAILABLE ON REQUEST

NOTE: RIGHT HAND HOLDERS USE LEFT HAND INSERTS. LEFT HAND HOLDERS USE RIGHT HAND INSERTS.